

Electronic Speed Controller

电子调速器

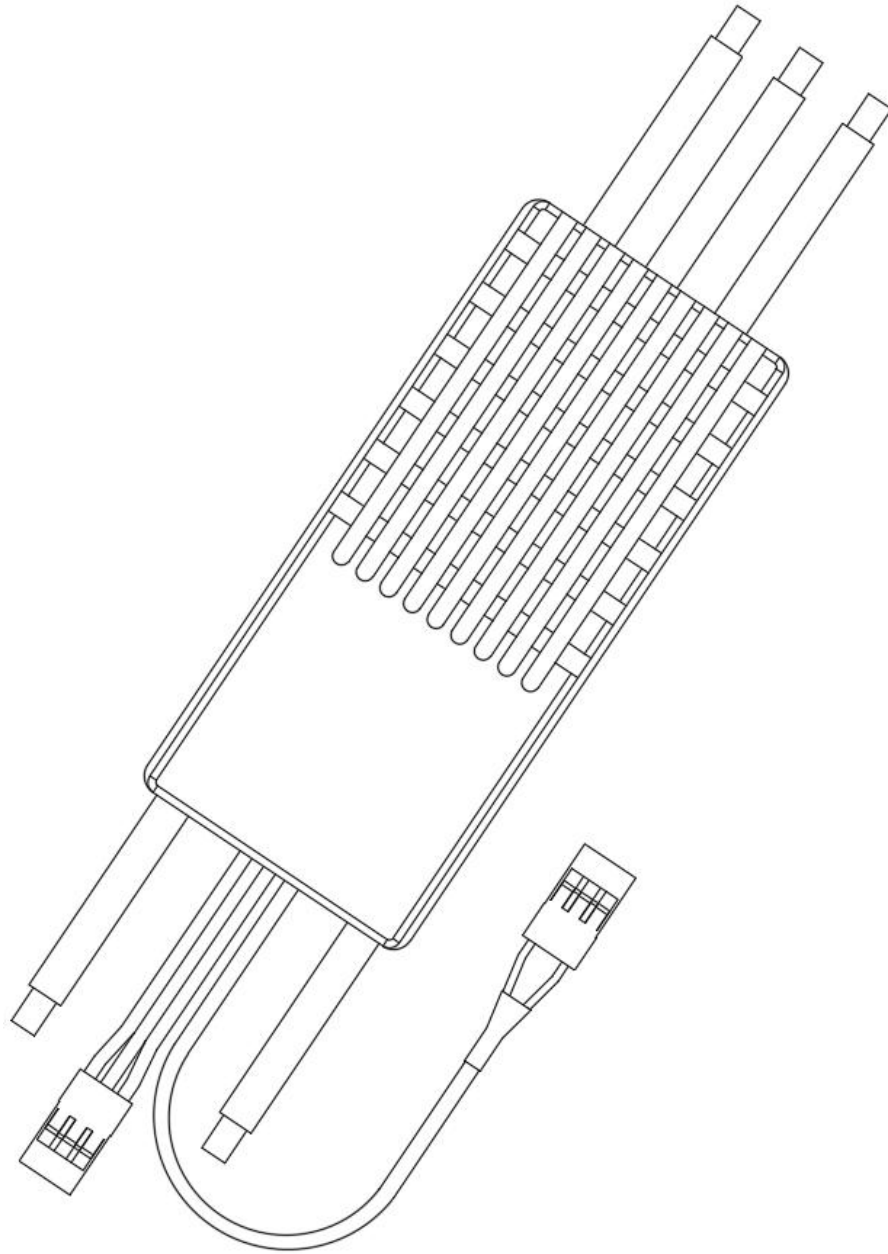

STONE series-磐石系列

使用手册-User Manual

V2.0

Thank you for using this product! Brushless power systems are powerful and incorrect use may result in personal injury and equipment damage. For this reason, we strongly recommend that you read this manual carefully before using the equipment. We do not assume any liability arising from the use of this product, including, but not limited to, liability for incidental or consequential damages; at the same time, we do not assume any liability arising from unauthorized modifications to the product and misuse.

We reserve the right to change product design, appearance, performance and usage requirements without notice.

Product Features

- Lightweight design, easy to use, stable and reliable, High anti-interference capability, Good speed control performance.
- Multiple security protections: low voltage protection、high voltage protection、activation protection、blocking protection、overtemperature protection、overcurrent protection、overload protection、runaway Protection.
- Optically isolated signal input and output interfaces.
- Serial output of real-time data: Supply Voltage、Motor RPM、current、ESC temperature and debugging data,etc.

Specification

Model No.	Weight	Main size	Operating Voltage	max. current(See specifications for details)	throttle stroke	Standby Current
STONE 80A-L	112g	90.4*36*18.5mm	4-6SL iPo	80A (continuous current)	1000-2000us PWM (calibratable) 50-500Hz	14mA@25V
STONE 60A-M	79g	71*33*15.5mm	6-14SL iPo	60A (continuous current)		15mA @20V
STONE 80A-M	95g	78*35*17mm	6-14SL iPo	80A (continuous current)		10mA @60V
STONE 100A-M	125g	90*40*19mm	6-14SL iPo	100A (continuous current)		
STONE 180A-M	232g	120*49*23.5mm	6-14SL iPo	180A(Maximum current 3 seconds)		
STONE 200A-M	247g	120*56*24.5mm	6-14SL iPo	200A(Maximum current 3 seconds)		
STONE 80A-MC	112g	90.4*36*18.5mm	6-14SL iPo	80A (continuous current)		

*See specifications for detailed parameters

protective function

- low voltage protection: Close by default (Customizable opening) .
- high voltage protection: Motor start-up is prohibited if the supply voltage exceeds the permissible value.
- activation protection : Unsuccessful startup, limiting startup current and automatic restart.
- blocking protection : Blocking occurs during normal operation (generally due to external forces) Try to restart (note that blocking at high throttle may damage the ESC).

- overtemperature protection: temperature exceeds 125°C, the maximum output power slowly decreases, up to 40% of full throttle power, and the temperature decreases After the temperature is reduced, the original power is restored.
- overcurrent protection: Limit the peak current from exceeding the limit value.
- overload protection: When an overloaded motor is recognized, Will limit maximum throttle to protect the powertrain.
- runaway protection: Gradual reduction of output power after 200ms of signal loss, Reduce the throttle quickly to less than 50% in 1 to 2 seconds, then slowly reduce the throttle to a stop.

interface definition

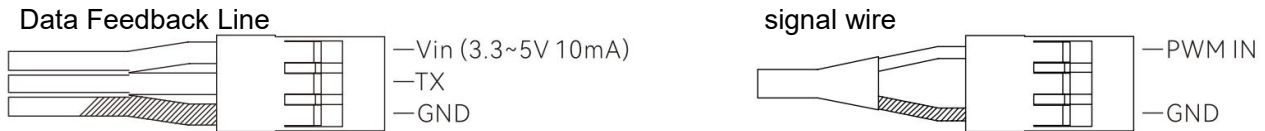

The striped line in the graph indicates the black line

Wiring Method

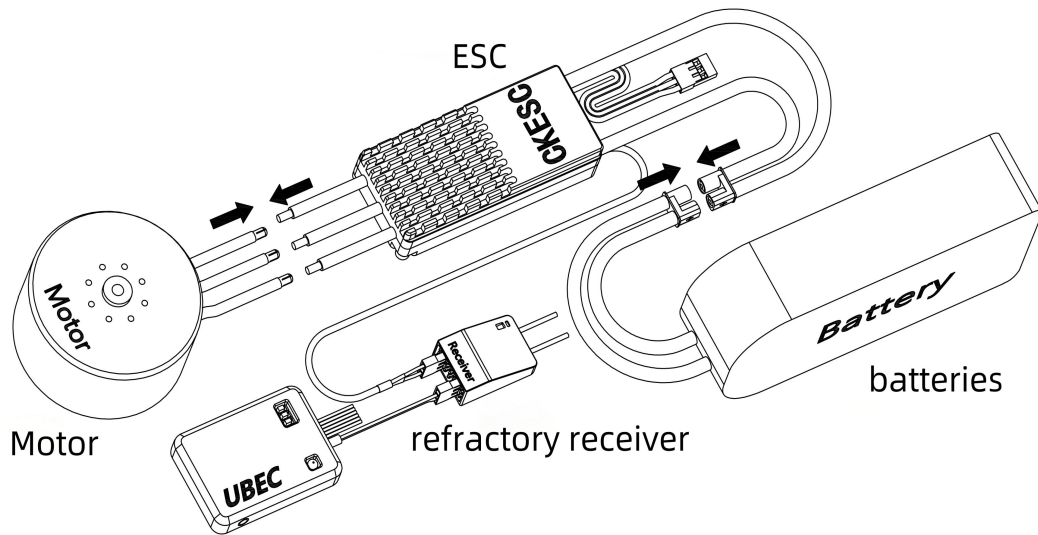

Throttle calibration

- Adjust the throttle signal to the maximum value Power on will initiate throttle correction, The motor will emit a “123-3-3-3”, Immediately afterward, the throttle signal is minimized, The motor will play the music “3-3-5-4”, After the music ends, the throttle travel correction is complete.
- Throttle travel must be calibrated for accurate control before using and replacing the remote control (throttle signal sending device) for the first time.

Data output

- Data output using 3-wire UART-TTL, baud38400bps, character method.
- Packet format: SPD:XXXX TMOS:XXXX TMOT:XXXX TMCX:XXXXXXXXXXXXX CURI:XXXX
VOLT:XXXX PWAC:XXXX SYS:XXXXXXXXXXXXX DBG:XXXXXXXXXXXXX

included among these:

SPD:XXXX Motor speed (RPM, inaccuracies±12RPM, Converted from 42P motor poles)

TMOS:XXXX ESC temperature (°C, inaccuracies±1°C)

TMOT:XXXX Motor temperature (°C, inaccuracies±1°C, Data retention)

TMCX:XXXXXXXXXXXX (Debugging data)

CURI:XXXX Motor Current (×0.01A, inaccuracies±10%, Mainly used for ESC overcurrent protection)

VOLT:XXXX Supply Voltage (×0.01V, inaccuracies±0.5V)

PWAC:XXXX (Debugging data)

SYS:XXXXXXXXXXXX (Debugging data)

DBG:XXXXXXXXXXXX (Debugging data)

Fault phenomenon

fault phenomenon	warning tone	Possible causes	method settle an issue
It's not responding when it's energized.	none	ESC not powered on Internal power system failure	Check and turn on the power Return to factory for repair
Power on beep, gas door No alarm tone even if not started	♪123-	Throttle not zeroed, waiting for zero throttle to unlock or high throttle to enter throttle stroke calibration	Check the PWM signal value of the confirmation source, or recalibrate the throttle stroke
Power on beep is normal, gas door does not start and alarm beeps	♪123-3 ♪11111-preservation (accelerator)	High power supply voltage detected and prohibits startup	Check the power supply voltage, the or return to factory for repair
Continuous alarm tone when energized	♪123- ♪1shortness1elder (preservation)	PWM signal is continuously low	Checking the signal wiring
Continuous alarm tone when energized	♪123- ♪1elder1shortness (preservation)	PWM signal continuously high	Checking the signal wiring
Continuous alarm tone after deceleration and shutdown during operation	♪1shortness (intervals1s)	Loss of throttle signal.	Checking the signal wiring
Alarm beeps when throttle is zeroed out and shut down Alarm tone	♪3-1-3-1 (intervals1s)	Early warning, throttle signal during operation Unstable	Check signal wiring, or return to factory for service

Safety advice

- Signal pulse width and frequency must meet the requirements. Do not pull and tug the control signal line, make sure the ESC signal line is connected reliably without loosening, in order to prevent the production of interference signals leading to abnormal control. Ensure that the ESC signal cable is connected reliably and without looseness, so as to prevent the generation of interfering signals leading to abnormal control.
- The power connection can be made using an anti-ignition plug, but make sure the connection is reliable (poor connection will lead to plug ablation and even power failure); the output phase wires do not use anti-ignition plugs, do not plug and unplug with electricity. Ensure that the power supply voltage is stable (if it is battery-powered, note that the battery discharge multiplier should be high and the low-temperature discharge performance should be good), otherwise it may lead to power failure. should be good), otherwise it may lead to ESC damage.
- Ensure good heat dissipation of the ESC, the ESC working at high temperature for a long time will accelerate the aging of the components and significantly reduce the service life of the ESC. It is recommended to monitor the working temperature in real time.degree, according to the real-time output temperature data, determine whether the current working conditions are safe (temperature below 100 °C is safer, higher than 100 °C for poor heat dissipation or load). overload, more than 115 °C is not safe).
- It is prohibited to short-circuit the output phase wires before the residual power of the ESC is discharged, which may cause damage to the ESC.
- The following precautions should be taken when this product is applied to a flying machine:
 - ① Please use reasonable configuration with ESC to get the best performance (force efficiency, power, safety). If you use mismatched motors, propellers (not even propeller loads or variable loads) or non-correct voltage, you may not achieve optimal performance or even damage the ESC.
 - ② Before each flight it is recommended to check all parts of the aircraft structure for looseness, deterioration or damage, etc. The arm and propeller fixing screws must be locked firmly.
 - ③ Always use a stabilized load, and close the throttle or disconnect the power as soon as possible when the propeller is externally blocked to prevent damage to the ESC due to excessive blocking current.
- Overloading is strictly prohibited, otherwise product performance and safety will not be guaranteed.
- Please do not disassemble and modify the product without authorization, otherwise the performance and safety of use and warranty service cannot be guaranteed.